

*Recognized as an
American National Standard (ANSI)*

IEEE Std 1344-1995(R2001)

IEEE Standard for Synchrophasors for Power Systems

Sponsor

**Power System Relaying Committee
of the
IEEE Power Engineering Society**

Approved 12 December 1995

IEEE Standards Board

Reaffirmed 17 March 2001

IEEE-SA Standards Board

Abstract: *The synchronizing input and the data output for phasor measurements made by substation computer systems is discussed. Processes involved in computing phasors from sampled data, data-to-phasor conversions, and formats for timing inputs and phasor data output from a Phasor Measurement Unit (PMU) are also addressed.*

Keywords: *anti-aliasing, digital computer based measurement, Global Positioning System (GPS), Nyquist rate, phase lock, phasor, satellites, synchronism, synchronized phasor, time input*

*The Institute of Electrical and Electronics Engineers, Inc.
345 East 47th Street, New York, NY 10017-2394, USA*

*Copyright © 1995 by the Institute of Electrical and Electronics Engineers, Inc.
All rights reserved. Published 1995. Printed in the United States of America*

ISBN 1-55937-693-7

No part of this publication may be reproduced in any form, in an electronic retrieval system or otherwise, without the prior written permission of the publisher.

IEEE Standards documents are developed within the Technical Committees of the IEEE Societies and the Standards Coordinating Committees of the IEEE Standards Board. Members of the committees serve voluntarily and without compensation. They are not necessarily members of the Institute. The standards developed within IEEE represent a consensus of the broad expertise on the subject within the Institute as well as those activities outside of IEEE that have expressed an interest in participating in the development of the standard.

Use of an IEEE Standard is wholly voluntary. The existence of an IEEE Standard does not imply that there are no other ways to produce, test, measure, purchase, market, or provide other goods and services related to the scope of the IEEE Standard. Furthermore, the viewpoint expressed at the time a standard is approved and issued is subject to change brought about through developments in the state of the art and comments received from users of the standard. Every IEEE Standard is subjected to review at least every five years for revision or reaffirmation. When a document is more than five years old and has not been reaffirmed, it is reasonable to conclude that its contents, although still of some value, do not wholly reflect the present state of the art. Users are cautioned to check to determine that they have the latest edition of any IEEE Standard.

Comments for revision of IEEE Standards are welcome from any interested party, regardless of membership affiliation with IEEE. Suggestions for changes in documents should be in the form of a proposed change of text, together with appropriate supporting comments.

Interpretations: Occasionally questions may arise regarding the meaning of portions of standards as they relate to specific applications. When the need for interpretations is brought to the attention of IEEE, the Institute will initiate action to prepare appropriate responses. Since IEEE Standards represent a consensus of all concerned interests, it is important to ensure that any interpretation has also received the concurrence of a balance of interests. For this reason IEEE and the members of its technical committees are not able to provide an instant response to interpretation requests except in those cases where the matter has previously received formal consideration.

Comments on standards and requests for interpretations should be addressed to:

Secretary, IEEE Standards Board
445 Hoes Lane
P.O. Box 1331
Piscataway, NJ 08855-1331
USA

Note: Attention is called to the possibility that implementation of this standard may require use of subject matter covered by patent rights. By publication of this standard, no position is taken with respect to the existence or validity of any patent rights in connection therewith. The IEEE shall not be responsible for identifying all patents for which a license may be required by an IEEE standard or for conducting inquiries into the legal validity or scope of those patents that are brought to its attention.

Authorization to photocopy portions of any individual standard for internal or personal use is granted by the Institute of Electrical and Electronics Engineers, Inc., provided that the appropriate fee is paid to Copyright Clearance Center. To arrange for payment of licensing fee, please contact Copyright Clearance Center, Customer Service, 222 Rosewood Drive, Danvers, MA 01923 USA; (508) 750-8400. Permission to photocopy portions of any individual standard for educational classroom use can also be obtained through the Copyright Clearance Center.

Introduction

(This introduction is not a part of IEEE Std 1344-1995, IEEE Standard for Synchrophasors for Power Systems.)

Digital computer-based measurement, protection, and control systems have become common features of electric power substations. These systems use sampled data to compute various quantities such as voltage and current phasors. Phasors are of great value in many functions, and their utility is increased further if they can be referenced to a common time base. This can be accomplished if the signal input processes at various measuring sites are synchronized with respect to each other. Simultaneous measurement sets derived from synchronized phasors provide a vastly improved method for tracking power system dynamic phenomena for improved power system monitoring, protection, operation, and control.

The standard defines the synchronizing input and the data output for phasor measurements made by substation computer systems. It also discusses the processes involved in computing phasors from sampled data. It is hoped that this standard will be of considerable value to the developers and users of digital computer-based substation systems.

The members of the Synchrophasor Working Group that developed this standard are as follows:

A. G. Phadke, *Chair*
K. Martin, *Vice Chair*

M. G. Adamiak
G. Benmouyal
M. Bergovic
R. O. Burnett, Jr.
K. R. Carr

A. Cobb
S. H. Horowitz
G. R. Jensen
J. A. Kuster
G. L. Michel

R. J. Murphy
M. S. Sachdev
J. S. Thorp

The members of the Relaying Communications Subcommittee who reviewed this standard are as follows:

J. W. Hohn, *Chair*
M. Adamiak, *Vice Chair*

P. R. Drum
J. D. Huddleston, III
J. W. Ingleson
G. L. Michel
J. L. McElray

B. D. Nelson
S. L. Nilsson
A. G. Phadke
R. Ryan
E. T. Sage

J. T. Tengdin
E. A. Udren
J. A. Zipp

The members of the PES/IEEE Power System Relaying Committee who reviewed and approved this standard are as follows:

A. T. Giuliante, *Chair*
J. C. Appleyard, *Vice Chair*
R. W. Dempsey, *Secretary*

M. Adamiak
C. W. Barnett*
E. A. Baumgartner
B. L. Beckwith
G. Benmouyal
J. Berdy*
D.C. Blackburn
J. L. Blackburn*
J. Blose*
J. R. Boyle
B. Bozoki
W. R. Brownlee*
J. Burnworth
H. J. Calhoun
C. H. Castro
T. W. Cease
J. W. Chadwick, Jr.
G. K. Clough
D. H. Colwell*
S. P. Conrad
M. Conroy
C. J. Cook
A. N. Darlington
D. C. Dawson
R. E. Dietrich*
J. B. Dinger*
H. Disante*
C. L. Downs*
P. R. Drum
L. L. Dvorak
W. A. Elmore
J. T. Emery*
E. J. Emmerling*
M. K. Enns
J. Esztergalyos
G. Farley
W. E. Feero*
R. J. Fernandez*
C. W. Fromen

S. E. Grier
C. H. Griffin*
K. R. Gruesen*
E. N. Gulachenski
E. A. Guro
R. W. Haas
E. L. Harder*
R. E. Hart
C. F. Henville
R. W. Hirtler*
J. W. Hohn
S. H. Horowitz*
J. D. Huddleston, III
J. W. Ingleson
J. A. Jodice
E. W. Kalkstein
T. L. Kaschak
M. Kezunovic
K. J. Khunkhun
J. L. Koepfinger*
W. C. Kotheimer
P. Kotos
L. E. Landoll*
J. R. Latham
J. R. Linders
G. J. Marieni*
W. J. Marsh, Jr.
C. A. Matthews*
G. E. May*
J. McConnell
J. McElray
M. Meisinger
W. Mello
R. J. Moran
J. J. Murphy*
T. J. Murray
K. K. Mustaphi
G. R. Nail
B. Nelson

T. Niessink*
S. L. Nilsson
R. W. Ohnesorge*
G. C. Parr
R. W. Pashley*
R. D. Pettigrew
A. G. Phadke
A. C. Pierce
J. M. Postforoosh
O. F. Pumphrey*
G. D. Rockefeller*
M. S. Sachdev
M. P. Sanders
E. T. Sage
M. Sanders
D. E. Sanford*
D. Smaha
H. S. Smith*
J. E. Stephens
W. M. Strang
F. Y. Tajaddodi
R. P. Taylor
J. T. Tingdin
J. S. Thorp
D. A. Tziouvaras
E. A. Udren
W. H. Van Zee*
V. Varneckas
D. R. Volzka*
F. Von Roeschlaub*
C. L. Wagner
J. W. Walton
W. P. Waudby
T. E. Wiedman
P. B. Winston
J. A. Zipp
S. E. Zocholl*
J. A. Zulaski

*Honorary Member (non-voting)

The following persons were on the balloting committee:

J. C. Appleyard	S. E. Grier	A. G. Phadke
E. A. Baumgartner	E. N. Gulachenski	A. C. Pierce
B. L. Beckwith	E. A. Guro	J. M. Postforoosh
J. R. Boyle	R. E. Hart	M. S. Sachdev
B. Bozoki	C. F. Henville	E. T. Sage
J. A. Bright	R. W. Hirtler	D. Smaha
H. J. Calhoun	J. W. Hohn	H. S. Smith
C. H. Castro	J. D. Huddleston, III	J. E. Stephens
T. W. Cease	J. W. Ingleson	W. M. Strang
J. W. Chadwick, Jr.	J. A. Jodice	F. Y. Tajaddodi
G. K. Clough	E. W. Kalkstein	R. P. Taylor
S. P. Conrad	K. J. Khunkhun	J. S. Thorp
C. J. Cook	W. C. Kotheimer	E. A. Udren
A. N. Darlington	J. R. Latham	V. Varneckas
D. C. Dawson	J. R. Linders	D. R. Volzka
R. W. Dempsey	W. J. Marsh, Jr.	C. L. Wagner
C. L. Downs	R. J. Moran	J. W. Walton
P. R. Drum	C. J. Mozinz	W. P. Waudby
L. L. Dvorak	T. J. Murray	T. E. Wiedman
W. A. Elmore	K. K. Mustaphi	J. A. Zipp
J. Esztergalyos	G. R. Nail	S. E. Zocholl
G. Farley	S. L. Nilsson	J. A. Zulaski
C. W. Fromen	G. C. Parr	
A. T. Giuliante	R. D. Pettigrew	

When the IEEE Standards Board approved this standard on 12 December 1995, it had the following membership:

E. G. "Al" Kiener, Chair
Donald C. Loughry, Vice Chair
Andrew G. Salem, Secretary

Gilles A. Baril	Jim Isaak	Mary Lou Padgett
Clyde R. Camp	Ben C. Johnson	John W. Pope
Joseph A. Cannatelli	Sonny Kasturi	Arthur K. Reilly
Stephen L. Diamond	Lorraine C. Kevra	Gary S. Robinson
Harold E. Epstein	Ivor N. Knight	Ingo Rüsçh
Donald C. Fleckenstein	Joseph L. Koepfinger*	Chee Kiow Tan
Jay Forster*	D. N. "Jim" Logothetis	Leonard L. Tripp
Donald N. Heirman	L. Bruce McClung	Howard L. Wolfman
Richard J. Holleman	Marco W. Migliaro	

*Member Emeritus

Also included are the following nonvoting IEEE Standards Board liaisons:

Satish K. Aggarwal	Robert E. Hebner
Steve Sharkey	Chester C. Taylor

Lisa S. Young *IEEE Standards Project Editor*

CLAUSE	PAGE
1. Overview	1
1.1 Scope	1
1.2 Purpose	1
1.3 Need for this standard	1
2. References	1
3. Definitions	2
4. Sources of synchronizing signals	3
4.1 Requirements for a synchronizing source	3
4.2 Broadcasts from satellites	3
4.3 Broadcasts from a central location	4
5. Synchronization	4
5.1 UTC synchronization	4
5.2 Phase-locked sampling pulses	4
5.3 Time input	6
5.4 Time-tag for data samples	7
5.5 Time-tag for phasors	7
6. Message format	8
6.1 Transmitted messages	8
6.2 Data frame	8
6.3 Header frame	9
6.4 Configuration frame	10
6.5 Received messages	11
Annex A (Informative)	12
Annex B (Informative)	13
Annex C (Informative)	14
Annex D (Informative)	16
Annex E (Informative)	21
Annex F (Informative)	25
Annex G (Informative)	30

IEEE Standard for Synchrophasors for Power Systems

1. Overview

1.1 Scope

This is a standard for synchronized phasor measurement systems in substations. It addresses synchronization of data sampling, data-to-phasor conversions, and formats for timing input and phasor data output from a Phasor Measurement Unit (PMU). It does not specify response time, accuracy, hardware, software, or a process for computing phasors.

1.2 Purpose

This standard defines synchronized phasor measurements in substations so that the measurement equipment can be readily interfaced with associated systems. It specifies data formats and synchronization requirements to allow correlating phasors from various sources and comparing them with similar data from different measurement systems.

1.3 Need for this standard

Recent developments in the field of power system data acquisition provide users with the ability to record, time-tag, transmit, and analyze power system phasor quantities in real time. Given the emphasis on future system development, many different hardware and software approaches are being implemented to make the phasor data available. A standard is needed for integrating measurement systems into substation environments, to specify data output formats, and to assure that the measurement processes are producing comparable results. The synchrophasor standard will help ensure maximum benefits from the phasor measurements and will allow interchange of data between a wide variety of users of both real time and off-line phasor measurements.

2. References

This standard shall be used in conjunction with the following publications:

IEEE Std C37.111-1991, , IEEE Standard Common Format for Transient Data Exchange (COMTRADE) for Power Systems (ANSI).¹

IRIG STANDARD 200-89, Telecommunications Group, Range Commanders Council, U.S. Army White Sands Missile Range, NM.²

Network Time Protocol (Version 3) "Specification, Implementation, and Analysis," D. L. Mills, DARPA Network Working Group, RFC-1305, University of Delaware, March, 1992.³

3. Definitions

This clause contains key terms as they are used in this standard.

3.1 anti-aliasing: By the Nyquist Theorem, the maximum reproducible frequency is one-half the sampling rate. Aliasing is caused when frequencies higher than one half of the sampling rate are present. This results in the higher frequencies being "aliased" down to look like lower frequency components. Anti-aliasing is providing low pass filtering to block out frequencies higher than those that can be accurately reproduced by the given sampling rate.

3.2 Nyquist rate: The minimum rate that an analog signal must be sampled in order to be represented in digital form. This rate is twice the frequency of that signal.

3.3 phase lock: The state of synchronization between two ac signals in which they remain at the same frequency and with constant phase difference. This term is typically applied to a circuit that synchronizes a variable oscillator with an independent signal.

3.4 phasor: A complex equivalent of a simple sine wave quantity such that the complex modulus is the sine wave amplitude and the complex angle (in polar form) is the sine wave phase angle. *See also: vector.*

3.5 synchronism: The state where connected alternating-current systems, machines, or a combination operate at the same frequency and where the phase angle displacement between voltages in them are constant, or vary about a steady and stable average value.

3.6 synchronized phasor: A phasor calculated from data samples using a standard time signal as the reference for the sampling process. In this case, the phasors from remote sites have a defined common phase relationship. *Syn: synchrophasor.*

3.7 abbreviations and acronyms:

- BCD: Binary Coded Decimal
- CRC₁₆: 16 b Cyclic Redundancy Check, calculated by the generating polynomial $X^{16} + X^{12} + X^5 + 1$
- DoD: Department of Defense
- DoT: Department of Transportation
- FRP: Federal Radionavigation Plan
- GOES: Geostationary Operational Environmental Satellite—consists of two satellites in a geostationary orbit.
- GPS: Global Positioning System—a DoD navigation system that uses a constellation of 24 satellites broadcasting a precision signal for location and time synchronization. Basic time synchronization accuracy is $\pm 0.2 \mu\text{s}$.
- INMARSAT: International Maritime Satellite System
- IRIG-B: InterRange Instrumentation Group Time Code Format B

¹IEEE publications are available from the Institute of Electrical and Electronics Engineers, 445 Hoes Lane, P.O. Box 1331, Piscataway NJ 08855-1331, USA.

²This IRIG standard may be obtained from Secretariat, Range Commanders Council, U.S. Army White Sands Missile Range, NM, 88002, USA.

³This document is available from EE Department, University of Delaware, Newark, DL, 19716, USA. It is also available via the World Wide Web: <http://www.eeis.udel.edu/~mills.bib.html>.

- Loran C: LOnG RANge navigation system that uses pulsed 100 kHz broadcasts from shore based transmitters for location, particularly in maritime applications. It also provides precise frequency and limited time synchronization.
- NTP: Network Time Protocol
- PMU: Phasor Measurement Unit—in this standard a generic device that produces synchronized phasors from voltage and/or current inputs and synchronizing signal.
- PPS: Pulse Per Second
- ROM: Read Only Memory
- SA: Selective Availability
- SBS: Straight Binary Seconds
- SCADA: Supervisory Control and Data Acquisition
- SMPCNT: Sample Count
- SOC: Second-Of-Century
- UTC: Universal Time Coordinated as distributed by the U.S. Naval Observatory through the GPS system
- WWV: Radio broadcast of time and selected weather information. They are provided by the U.S. National Institute for Standards and Technology using several formats including WWV, WWVB, and WWVH.

4. Sources of synchronizing signals

4.1 Requirements for a synchronizing source

Phasors measured throughout an interconnected grid require a common timing reference provided by a synchronizing source. The synchronizing source may be local or global, and the signal may be distributed by broadcast or direct connection.

The signal provided by the synchronizing source shall be referenced to Coordinated Universal Time (UTC). It shall provide enough time information to determine second-of-century in agreement with UTC. The synchronizing signal shall have a basic repetition rate of 1 pulse per second (1 PPS) with a stability of at least $1\text{E}-07$.

The synchronizing signal must be available without interruption at all measurement locations throughout the interconnected grid. Reliability should exceed 99.87% (1 h of outage per month). The signal shall be accurate enough to allow the phasor measurement equipment to maintain synchronism within $1\ \mu\text{s}$ of UTC including both synchronizing source and local receiving equipment error.

4.2 Broadcasts from satellites

Time signals broadcast from satellites have a wide area of coverage, are synchronized to a national standard, and are little affected by atmospheric conditions. Sites with unobstructed views of satellites have little problem with reliable, continuous signal reception. Users of satellite based systems do not have to provide primary time and time dissemination systems, nor do they have to operate and maintain those systems. The only user cost is for the receiver equipment, although fees may be levied in future satellite systems.

Transit, Geostationary Operational Environmental Satellite (GOES), and Global Positioning System (GPS) are the three principal satellite systems available today for disseminating time. Once policy issues are resolved, INMARSAT system satellites will provide precise time in a GPS-like navigation message. Of the three systems available now, only GPS meets all requirements for this application.

The GPS is a U.S. Department of Defense (DoD) satellite based radio-navigation system. It consists of 24 satellites arrayed to provide a minimum worldwide visibility of four satellites at all times. Each satellite transmits a timed navigation signal, from which a receiver can decode time synchronized to within 0.2 ms of UTC. The inherent availability, redundancy, reliability, and accuracy make it a system well suited for synchronized phasor measurement systems.

The new INMARSAT system satellites will carry a GPS-like transponder. The signal will be similar to existing GPS transmissions, so it can be used with slightly modified GPS receivers. Since the signal will not be degraded by the effects of SA, it should be a better source for time than standard GPS. INMARSAT satellites are geostationary, which may make reception difficult at some locations. The INMARSAT system will provide an alternative to GPS.

4.3 Broadcasts from a central location

Synchronizing signals may also be broadcast from a central location. The viable alternatives include AM radio broadcasts, microwave, and fiber-optic transmission systems. While AM broadcasts are the least expensive, they are characterized by the lowest accuracy. Microwave and fiber-optics systems can achieve high accuracy but have high installation costs.

The most popular and affordable AM systems, WWV, WWVB, and WWVH, rarely achieve accuracy better than 1 ms. Interference poses problems with the reliability of reception. The Loran C impulse broadcast system is well supported by a number of countries, including the U.S., through the end of the century and is a popular navigation system. Its practical accuracy limit is of the order of 1 μ s, but careful monitoring and well-designed human interfaces are required for the best performance.

Fiber-optic and microwave systems can deliver synchronization reliably at 1 μ s and better. This, however, requires a specialized interface that bypasses the usual digital telecommunication interface. The problem with the usual digital interface is its packet switching, which can cause a 70 μ s uncertainty in signal transmission. Until digital systems are developed with a standard, direct, synchronizing signal, this method of transmission will remain expensive.

5. Synchronization

5.1 UTC synchronization

Phasor measurements shall be synchronized to UTC time derived from the synchronizing source described in 4.1. A PMU may receive the synchronizing signal directly or from an independent receiver. If an independent receiver is used, it shall provide time to the PMU using the codes described in 5.3. The basic synchronizing signal is a 1 PPS pulse train where the rising edge of the pulse marks the second change of UTC time. The PMU shall maintain a timing accuracy of 1 μ s between the synchronizing pulses. The 1 μ s synchronization accuracy has been chosen because it is available and meets all foreseeable data accuracy needs. This corresponds to an angular accuracy of 0.022 degrees for a 60 Hz system, and 0.018 degree for a 50 Hz system.

If synchronized phasors are calculated from synchronized data samples, the data sampling shall be synchronized to within 1 μ s of UTC time. Details for PMUs that use fixed frequency synchronized sampling are provided in 5.2, 5.4, and 5.5.

If synchronized phasors are calculated from non-synchronized data samples, the calculating process shall determine an equivalent UTC time and sample number as described for synchronized sampling techniques. The phasor thus determined shall have the same magnitude and phase angle as a phasor bearing the same time and sample number derived from synchronized samples using the same data window. Annex G includes a discussion of other techniques for achieving synchronization of phasor measurements.

5.2 Phase-locked sampling pulses

In synchronized sampling systems, pulses that trigger data sampling shall be locked in phase with the 1 PPS signal. The number of sample pulses per second shall be an integer and evenly spaced throughout the second. The sample point error shall not exceed 1% of the sample period (0.01/sampling rate). The samples shall be numbered from 0 to

$N-1$, where N is the sample rate. Sample 0 is the first sample in the new second and shall coincide with the rising edge of the 1 PPS pulse within ± 100 ns. It is recommended that the sample rate be chosen from the list of Least Common Multiple sample frequencies as defined in IEEE Std C37.111-1991⁴ (COMTRADE), repeated here in tables 1 and 2 for convenience.

Table 1—Sampling frequencies—corresponding to $f_{LCM} = 384 \times f_{base}$

Samples/Cycle	Sample 60 Hz	Frequency 50 Hz
4	240	200
6	360	300
8	480	400
12	720	600
16	960	800
24	1440	1200
32	1920	1600
48	2880	2400
64	3840	3200
96	5760	4800
128	7680	6400
192	11 520	9600
384	23 040	19 200

If time or sample pulses are provided by a device external to the PMU, a flag shall be provided to indicate a loss of time sync or phase lock. Upon loss of sync or lock, the PMU shall set a flag in the status word indicating that the resultant data was computed with "Un-Locked" data. If sampling is being resynchronized to the 1 PPS signal after a period of being unsynchronized, the sample pulses shall be slewed into alignment at a maximum rate of $70 \mu\text{s/s}$. The $70 \mu\text{s/s}$ will generate a 0.004 Hz computed frequency error but allows synchronization in 2 h from a worst case 0.5 s offset.

⁴Information on references can be found in clause 2..

Table 2—Sampling frequencies—corresponding to $f_{LCM} = 3200 \times f_{base}$

Samples/cycle	Sample 60 Hz	Frequency 50 Hz
4	240	200
8	480	400
10	600	500
16	960	800
20	1200	1000
32	1920	1600
40	2400	2000
50	3000	2500
64	3840	3200
80	4800	4000
100	6000	5000
128	7680	6400
160	9600	8000
200	12 000	10 000
320	19 200	16 000
400	24 000	20 000
640	38 400	32 000
800	48 000	40 000
1600	96 000	80 000
3200	192 000	160 000

5.3 Time input

UTC time and synchronization may be provided to the PMU using IRIG-B and 1 PPS or using the high-precision format time code. The IRIG-B format is commonly available and hence is the most readily implemented. The control bits are used to enhance standard IRIG-B with year, time zone, and other special flags. The high-precision format is an encoding technique compatible with fiber-optic systems that allows high-precision synchronization. The information format is the same as in IRIG-B. The formats are described in detail in annex F.

- *IRIG-B format.* IRIG-B is fully described in IRIG STANDARD 200-89. Time is provided once per second in seconds through day of year in a binary coded decimal (BCD) format. The BCD is amplitude modulated with a 1 kHz carrier signal.
- *1 PPS.* A one pulse per second positive pulse with the rising edge on time with the second change provides precise time synchronization. The pulse shall be 5 V with a 50 ns or less rise time and 5 μ s to 0.5 s duration.
- *High precision time code format.* The high precision format is the IRIG-B data format transmitted with modified Manchester coding. The clocking rate is 1 kHz with a rising data edge indicating a binary 1 and a falling data edge indicating a binary 0. Data edges are in phase with UTC. The high speed digital format eliminates the need for separate 1 PPS synchronization. This coding is a binary, zero-mean format that is easily transmitted over and recovered from cable or fiber-optic systems. Modulated and unmodulated IRIG-B can be regenerated from the code with simple circuits. It is recommended that PMU implementation include provision for decoding both time code formats.

5.4 Time-tag for data samples

Data shall be tagged with the UTC time during the second the sample was taken. The time-tag shall be a 4 B binary second-of-century (SOC) number derived in accordance with the network time protocol (NTP). This SOC number is the UTC time in seconds calculated from midnight of January 1, 1900. Leap seconds are added to or deleted from the scale as necessary to keep NTP synchronized with UTC. (This means NTP can always be determined by multiplying the number of seconds per day by the days since 1/1/1900. A leap second insertion will result in 2 s having the same SOC number.)

5.5 Time-tag for phasors

The time-tag for phasor data shall be composed of two words. The first is a 4 B word giving the SOC time in the NTP time scale. This is the same as the time-tag for data samples. The second word shall be 2 B SMPCNT giving the *sample number of the last sample used in the phasor calculation*. This is independent of the length of the data window used in the phasor calculation, as discussed in annex C. The sample taken on the 1 s mark is sample number 0. Using the convention that the signal $v(t) = \sqrt{2} V \cos(\omega_0 t + \varphi)$ corresponds to the phasor $V e^{j\varphi}$, the phasor computed from a window beginning at a positive voltage maximum is real while one computed from a window beginning at a positive going voltage zero is negative imaginary as shown in figure 1.

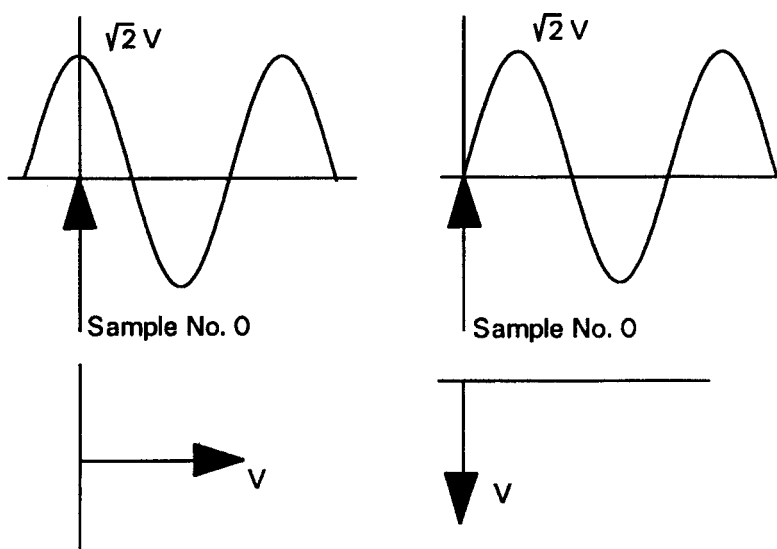

Figure 1—Convention for phasor representation

If the 1 PPS signal occurs at time t_0 , the measured phasor corresponding to a sinusoidal signal $v(t) = \sqrt{2} V \cos(\omega_0 t + \varphi)$ with a frequency ω_0 is $V e^{j(\omega_0 t_0 + \varphi)}$. For steady-state signals at off-nominal frequency ω_1 , the measured phasor with time-tag corresponding to the 1 PPS instant is $V e^{j(\omega_1 t_0 + \varphi)}$. The phasor phase angle shall be corrected for any phase angle delays occurring inside the PMU. The behavior of the measured phasor between the 1 PPS points and the response to non-steady-state (transient) conditions will vary with the algorithms used, and is discussed in annex C.

6. Message format

6.1 Transmitted messages

The PMU shall transmit three types of information organized as frames. The first 4 B of each frame are a SOC time mark. The 4 B SOC provides a distinct combination useful for frame synchronization. It is followed by the SMPCNT word that identifies the frame type and gives the sample number or the frame count. The three most significant bits of the SMPCNT word determine the frame type as defined in table 3. Every frame shall be terminated by a CRC₁₆ to validate the message. This CRC₁₆ uses the generating polynomial $X^{16} + X^{12} + X^5 + 1$.

Only data, configuration, and header frames are defined in this standard. Other types may be designated in the future using undesignated combinations in the SMPCNT word. In normal operation the PMU only sends data frames.

Table 3—SMPCNT word definition (message type is defined by the three most significant bits)

Bits 15–14–13	Frame type	Definitions
000	data frame	Bits 0–12: sample count, 0–8191
001	header frame	Bit 12: first frame flag (0: first frame of header file, 1: continuing frame) Bit 11: last frame flag (0: not last frame, 1: last frame of file) Bits 0–10: frame count for file, 0–2047 (first frame is count 0)
010	configuration frame	Bit 12: first frame flag (0: first frame of configuration file, 1: continuing frame) Bit 11: last frame flag (0: not last frame, 1: last frame of file) Bits 0–10: frame count for file, 0–2047 (first frame is count 0)
011–100	reserved for expansion	Bits 0–12: to be assigned
101–111	user defined	Bits 0–12: user defined

The header and configuration parameters shall be stored in the PMU. These formats generally follow the specifications of the Configuration file (*.CFG) and the Header file (*.HDR) of IEEE Std C37.111-1991 (COMTRADE).

Real-time data consisting of phasers, frequency estimates, and digital status shall be transmitted in data frames. Each frame is a data scan corresponding to the time-tag and sample number. The data shall be in binary format with no delimiters. Information for parsing and converting the information to engineering units shall be stored in the configuration file. The central data receiving system shall acquire the configuration file and store the information for operation. The header and configuration files may be transmitted during real time data transmissions, so the information will be interleaved with data frames. Since these files may be too large to send in one block between data frames, they can be broken into multiple frames for transmission. The minimum frame length for header or configuration frames is 9 B when a single byte is to be transferred. Examples of data, header, and configuration files are in annex D.

6.2 Data frame

A data frame shall contain measured data and shall be identified by having the three most significant bits of the third word (5th byte) equal to zero. The real-time phasor data frame shall consist of binary data arranged as shown in figure 2. SOC shall be the 4 B second-of-century time stamp as defined in 5.4. The sample count word, SMPCNT, shall be as defined in table 3 and the status word, STAT, shall be as defined in table 4. Data integrity shall be confirmed by using SMPCNT, SOC, and CRC₁₆.

Each phasor shall consist of 4 B: 2 B for the real part, and 2 B for the imaginary part, respectively; or, 2 B for magnitude, and 2 B for angle, respectively. Frequency (FREQ) and rate-of-change of frequency (DFREQ) shall be 2 B each. Digital channel data (DIG) shall be contained in 2 B words, one word for each 16 b channel. The cyclic redundancy check is the 2 B word CRC₁₆.

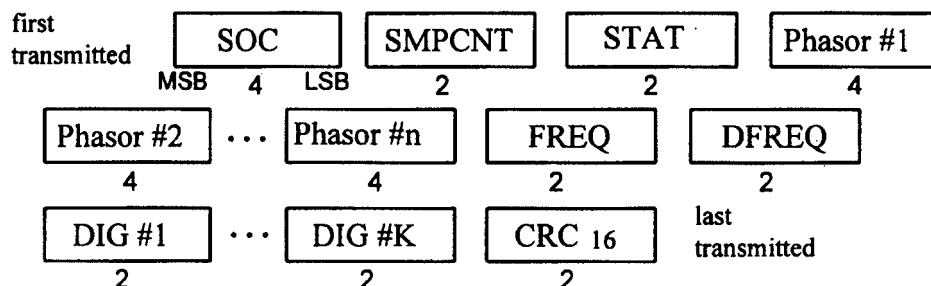

Figure 2—Data frame for phasor data

Table 4—Status word STAT definition

STAT bits	Definitions
bit 15	synchronization status (0: valid, 1: invalid)
bit 14	Data integrity (0: valid data, 1: invalid data)
bits 13–11	Trigger status: 111: Frequency trigger 110: df/dt trigger 101: Angle trigger 100: Overcurrent trigger 011: Undervoltage trigger 010: Rate trigger 000–001: Unused, user defined
bits 10–0	Number of bytes in frame including SOC, S MPCNT, STAT, and CRC ₁₆ , 10–2047

If the phasor is in real and imaginary format, each shall be a two's complement, 16 b binary number, with the scale defined by the configuration file. If the phasor is in magnitude and angle format, the magnitude shall be a 16 b binary number in the range 0 to $2^{15}-1$; and, the angle shall be in radians $\times 10^{-4}$ in the range $-\pi$ to $+\pi$. The frequency (FREQ) is a 16 b binary number in Hz $\times 10^{-3}$ deviation from system nominal. The system nominal frequency shall be given in the configuration file. The range shall be -32.767 to $+32.767$ Hz. The rate-of-change of frequency (DFREQ) shall be the rate of change in Hz per second $\times 10^{-2}$. The 16 b number thus defines a range of -327.67 to $+327.67$ Hz/s. The digital channel data shall reflect the state of the digital inputs (binary 0 or binary 1). The configuration file defines whether 0 or 1 is the normal state. Digital inputs shall be assigned starting at the least significant bit (b 0) of digital channel word. Zeroes shall be inserted in unused bits.

6.3 Header frame

This shall be an ASCII file, and shall contain information about the PMU, the data source, scaling, transducers, algorithms, analog filters used, etc. The frame has the same synchronizing SOC timetag, S MPCNT, STAT, and CRC₁₆, as the other frames, but the header file data has no fixed format (see figure 3).

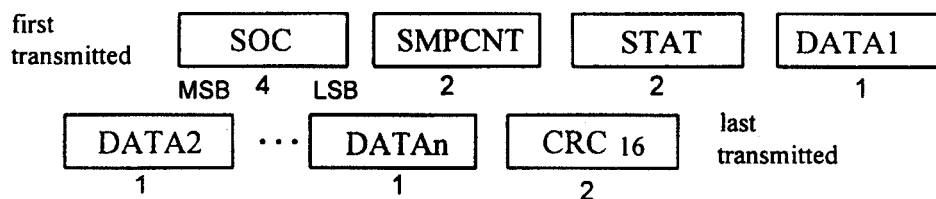

Figure 3—Header frame organization

6.4 Configuration frame

This shall be a machine-readable binary file containing information about processing parameters associated with the real-time data frame shown in figure 2. The configuration file shall have the following information:

- Station name and identification
- Number of phasors
- Number of digital channels
- Channel and phasor names, units, and conversion factors
- Nominal line frequency
- Transmission period in number of fundamental frequency cycles

There shall be two types of configuration files: a system configuration file CFG-1, and a data configuration file CFG-2. The CFG-1 file shall indicate all possible inputs. The CFG-2 shall indicate the phasors actually being sent since only a subset of available phasors may be transmitted by the PMU in the data frame. All fields shall be fixed length and no delimiters shall be used. SOC, SMPCNT, STATUS, and CRC₁₆ are as previously described. Other data types are as follows:

- STN: Station Name; 16 B in ASCII format.
- IDCODE: 8 B, PMU hardware identification, normally coded into the ROM.
- PHNMR: Number of phasors; 2 B integer word (0–32767).
- DGNMR: Number of digital channels; 2 B integer word (0–32 767).
- CHNAM: Phasor and channel names; 16 B for each phasor and each digital channel in ASCII format in the same order as they are transmitted.
- PHUNIT: Conversion factor for analog channels; 4 B for each phasor. The first byte designates voltage or current (00 = voltage; 01 = current). The last 3 B form a 24 b word in 10^{-5} V or amperes per bit.
- DIGUNIT: Conversion factor for digital channels; 2 B word for each digital channel. Bit 4 indicates the normal state in the digital word (0 or 1); bit 0 (least significant bit) designates the input normal state (0 = open, 1 = closed).
- FNOM: Nominal line frequency code and flag in two byte word. Bit 8 set (=1) indicates FREQ is omitted from the data frame and bit 9 set indicates DFREQ is omitted. Bit 0 (least significant bit) set indicates the fundamental line frequency is 50 Hz, and cleared indicates 60 Hz. The remaining bits can be used to designate other codes and frequencies.
- PERIOD: Period of phasor data transmissions; 2 B integer word (0–32 767) of the number of fundamental frequency cycles \times 100 between consecutive data transmissions (200 means a data frame every 2 cycles).

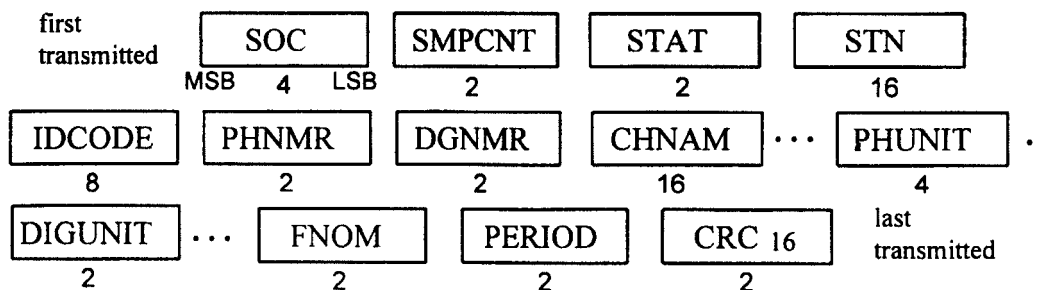

Figure 4— Configuration frame organization

The configuration file may be sent in several frames. The overall transmission has the organization shown in figure 4 but the configuration file data from STN through PERIOD may be broken into multiple frames. Each frame shall start with SOC, SMPCNT, and STAT, and end with CRC₁₆.

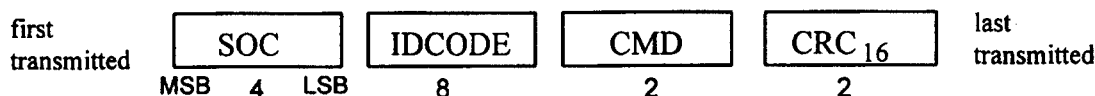

Figure 5— Received command frame definition

6.5 Received messages

The PMU shall receive commands from a control system and take appropriate actions. The received message frame is shown in figure 5. IDCODE shall be an 8 B identification code that shall be matched with a pre-stored code in the PMU for the command to be accepted by the PMU. The IDCODE shall be a unique code as determined by the user of the PMU. CMD shall be a 2 B command code as defined in table 5. SOC and CRC₁₆ are the timestamp and error check as previously described.

Table 5— Commands received by the PMU

Command word bits	Definition
Bits 15–4	Reserved for future use
Bits 3–2–1–0:	
0001	Turn off real-time data
0010	Turn on real-time data
0011	Send HDR file
0100	Send CFG–1 file
0101	Send CFG–2 file
1000	Receive reference phasor in data frame format

Annex A

(Informative)

Bibliography

[B1] Brigham, E. O. *The Fast Fourier Transform*, Prentice Hall, Inc., New York, 1974, p. 105.

[B2] "1992 Federal Radionavigation Plan," DoT-VNTSC-RSPA-92-2/DoD-4650.5, Stock No. 008-047-00402-8, U.S. Government Printing Office. Washington, D.C. 20402.

Annex B

(Informative)

Measurement accuracy and precision of synchronization

B.1 Measurement accuracy

Phasor accuracy is limited by the data sampling as follows. For a minimum error requirement E_{\min} and a full-scale rating F_s , the A/D converter needs the following:

$$\text{Minimum resolution} = \ln[(2\sqrt{2} F_s)/E_{\min}]/\ln(2) \quad (\text{B-1})$$

The factor $2\sqrt{2}$ scales the formula from rms to bipolar peak values, which is how A/D converters must be specified. For example, if the full-scale input F_s is 1.5 times the nominal input and a 1% resolution is required ($E_{\min}=0.01$), the minimum A/D resolution required is 9 b. Practical choices for number of bits are dictated by component availability and are typically 8, 12, 16, or 18 b.

This computation will be reasonably true for measuring bus voltage phasors since the magnitude typically varies little. Line currents are much more dynamic, with 10% of full load considered light load, short term overload ratings 2X–3X full load, and fault ratings 40X full load. Since phasor measurements are not very meaningful during faults, a reasonable scaling may set the full-scale 3X nominal and require a 1% accuracy at light load. This would add a factor of 10 to the full-scale accuracy and result in a 13 b requirement. The user needs to balance dynamic range requirements with system costs.

Other factors may have as great an effect on accuracy as data sampling. Anti-aliasing filters, harmonics, and phase imbalance can significantly effect the measurement. Without anti-aliasing filters, harmonics are aliased directly into the measurements. Power flow computed from positive-sequence phasors can be inaccurate if there are large phase imbalances. Anti-aliasing filters can introduce significant errors. For example, a 2 pole R-C filter with a cutoff frequency of 300 Hz will have a phase shift of about 22 degrees and a 2% magnitude rolloff at 60 Hz.

B.2 Required precision of synchronization

Measurement accuracy requirements are determined by the application. A tenth of a degree at the power system frequency is sufficient accuracy for state estimation, stability monitoring, control, and relaying. This requires a total synchronization error less than 5 μ s for a 60 Hz system. System hardware synchronization, sampling, and the data window all must be included in the synchronization uncertainty. Clauses 4 and 5 and annex G discuss synchronization further.

Annex C

(Informative)

Time tagging phasors

C.1 Transient response

As a consequence of the requirements of 5.1, two PMUs of different brands should be expected to yield the same phasor measurement in steady-state. Steady-state is a condition defined here as one where no change is taking place in magnitude, phase angle, or frequency. Also, identical PMUs (defined as having identical hardware and algorithms) should yield the same phasor measurement under all conditions. However, two PMUs of different brands (with different algorithms and/or different analog circuitry) can be expected to yield different results for the same phasor measurement in transient state (defined here as the time a change in magnitude, phase angle, or frequency takes place). Since this document does not point to a particular algorithm as a reference, an acceptable tolerance is not defined here and the amount of discrepancy to be expected from two PMUs can be evaluated only by inspection and analysis of the individual units. In particular the following should be analyzed:

- a) The type of sampling algorithm used and the value of the nominal sampling frequency. With conventional FIR type filtering (Discrete Fourier Transform, Least Squares Fitting, etc.), a fixed sampling rate will yield a phasor fixed in the complex plane only at rated frequency. This phasor normally undergoes an angular rotation, with the speed proportional to the frequency deviation when the frequency is different from rated. On the contrary, with an adaptive sampling rate where the number of samples per cycle is fixed whatever the incoming frequency, the measured phasor will be normally fixed in the complex plane, even if the frequency is different from rated frequency.
- b) The data window length.
- c) The type of filter used to get the phasor measurement. Particularly, the frequency response of the algorithm and its rejection of harmonics and off-nominal frequencies and its time response to a voltage or current step-function, together with the frequency response, should be investigated.

C.2 Alternate time-tags

Time-tagging the phasor measurement is an issue that is largely a matter of convention. Since a single measurement is the result of processing data in a time window, the time-tag may technically be associated with any of the samples that belong to the time window. The three most logical alternatives are as follows:

- a) Time-tag at the first sample of the window
- b) Time-tag in the middle of the window (at sample number $[N/2]$, or $[N/2]+1$, where N is the number of samples in the window)
- c) Time-tag at the last sample of the window

In practice, there is no reason why any of the alternatives would be given preference over any other. A few remarks may be helpful. Figure C-1 shows the phase response of a phasor measurement system to a waveform $x(t) = X_{\max} \cos \{\omega_0 t + 0.1 h(t-0.05)\}$, where $h(t)$ is a step-function that occurs at time $t=0$.

The waveform therefore represents a step change of phase angle of 0.1 rad at $t=0.05$. The response was calculated using a time window of 12 samples. The curves labeled "start of window," "center of window," and "end of window" represent the response when time-tag is associated with the first, sixth, and last sample of the window respectively. Obviously, the only difference between the methods occurs in the interval equal to two time windows centered around the moment of disturbance; phase angles before and after are calculated correctly.

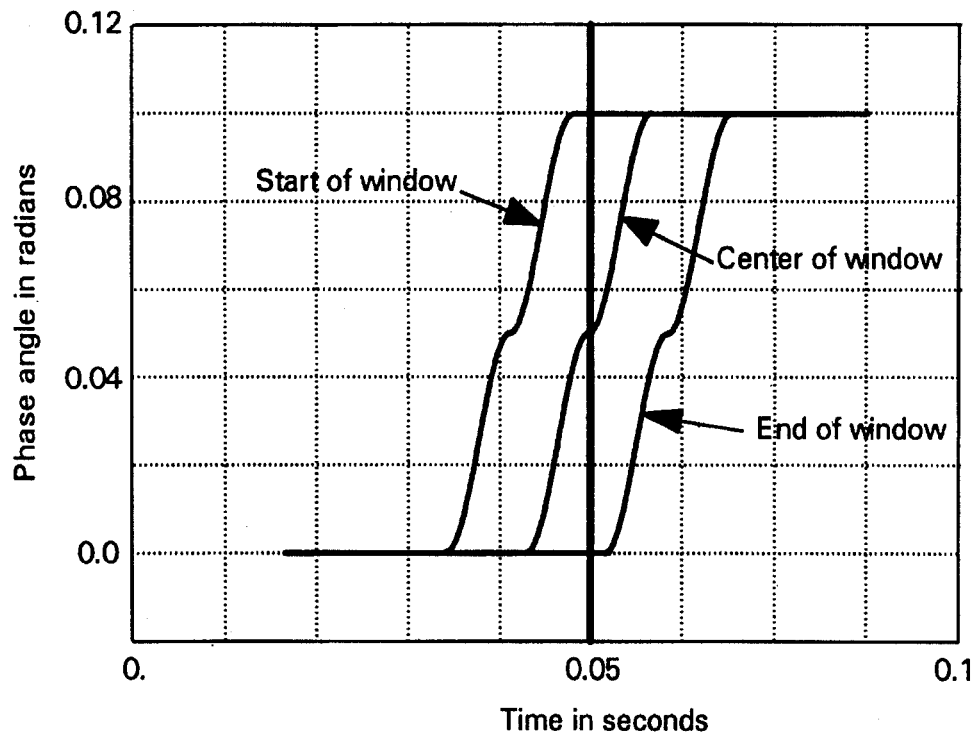

Figure C-1—Illustration of transient response of phasors

When monitoring is the only objective of phasor measurement, the choice of time-tag is irrelevant, as long as consistency is maintained. If measurement may be used for real time control, the following should be taken into account in interpreting the results:

- *Tracking*: From the point of view of "the best fit" between the original and measured waveforms, the time-tag in the center of the time window represents the best choice.
- *Causality*: When time-tag is associated with anything but the last sample of the window, the calculated response appears to begin before the actual disturbance occurs. Only when the tag is on the last sample does the response appear to begin after the occurrence of the disturbance.
- *Data Availability*: The phasors are available for further processing (real time control, etc.) only after the time window of measurement. Therefore, choosing time-tags before the end of the time window amounts to representing the phasor measurement system as a system with a delay for real time control purposes. This, of course, should be of no major concern given that the measurement time windows are normally very short compared to the dynamics of the system that may qualify for control.
- *Initiation*: Finally, the time-tag corresponding to the initiation of measurement corresponds to the first sample of the time window. This may be considered as a logical choice, with the proviso that when the objectives of the measurement encompass the above properties, appropriate compensatory action is taken.

Annex D

(Informative)

Supporting information for synchronized phasor data

Real time phasor data is transmitted according to the format shown in figure 2. Interpretation of the real time data involves various parameters for the data to be processed. These parameters are saved into two files in the phasor measurement systems. These files are "Configuration file" (*.CFG) and a "Header file" (*.HDR) that generally follow the specifications of IEEE Std C37.111-1991 (COMTRADE). The information may be accessed remotely, typically only at unit startup. Each file may be broken into several frames whose length is short enough to interleave with real time data.

In general, the selected data communication structure is designed to support the following requirements:

- a) Only measured and computed data should be transmitted in real time. Informational data should be transmitted only on request.
- b) All data must be traceable to an absolute time reference. The data transmitted should be in the most compact form possible to fit the available channel bandwidth. However, consideration must be given to optimization of host computer hardware and software.
- c) A wide range of basic sampling rates as well as data transmission rates must be supported.
- d) The format should support bi-directional real time control functions in a full-duplex communication mode.
- e) A mechanism to transmit bi-directional status information should be provided.
- f) Data integrity checks and an option for re-transmission should be provided.
- g) The amount and type of data transmitted over a sample interval must be user definable to adjust to the wide range of data requirements.

D.1 Header file

This is an ASCII file, and should contain information about the PMU, the data source, scaling, transducers, algorithms, analog filters used, etc. This file has no fixed format.

The following is an example of a header file:

```
DATA ORIGINATING FROM SUBSTATION XXX, COMPANY
YYY. CONTACT PERSON XYXY. PHONE NUMBER:
(XXX) XXX-XXXX. GPS SYNCHRONIZED PMU.
ANALOG FILTERS HAVE A PHASE LAG OF
10° ± 0.03° AT 60 Hz. NOMINAL FREQUENCY 60 Hz.
VOLTAGE CLASS 500 kV. XXC400 AND XXC800 TYPE CT.
CVTS MANUFACTURED BY YYY.
5 ANALOG CHANNELS AND 4 DIGITAL CHANNELS.
```

D.2 Configuration file

This is a machine-readable binary file, and contains the parameters associated with the data frame shown in figure 2. The file is structured as described in 6.4. Figure 4 illustrates the frame structure, and shows the additional frame header (SOC, SMPCNT, STAT) and trailer (CRC₁₆) words. When the file is transmitted as several frames, structure within each frame and the order of frames will preserve the original file structure.

The following is an example of a configuration file:

58 58 58 58 58 58 20 35 30 30 20 4B 56 20 20 20	XXXXXX-500-kV-
F2 45 AA 9D 2C 03 A9 4C	binary id
00 05	five phasors
00 04	four digital channels
20 42 55 53 20 56 4F 4C 54 41 47 45 20 20 20 20	BUS VOLTAGE
20 4C 49 4E 45 31 20 43 55 52 52 45 4E 54 20 20	LINE1 CURRENT
20 4C 49 4E 45 32 30 43 55 52 52 45 4E 54 20 20	LINE2 CURRENT
20 4C 49 4E 45 33 20 43 55 52 52 45 4E 54 20 20	LINE3 CURRENT
20 4C 49 4E 45 34 20 43 55 52 52 45 4E 54 20 20	LINE4 CURRENT
42 52 45 41 4B 45 52 31 20 20 20 20 20 20 20	BREAKER1
42 52 45 41 4B 45 52 32 20 20 20 20 20 20 20	BREAKER2
42 52 45 41 4B 45 52 33 20 20 20 20 20 20 20	BREAKER3
42 52 45 41 4B 45 52 34 20 20 20 20 20 20 20	BREAKER4
00 17 48 A5	voltage; 32 767 = 500 kV
01 00 0B EB	current; 32 767 = 1000A
01 00 77 36	current; 32 767 = 10000 A
01 00 05 F5	current; 32 767 = 500A
01 00 05 F5	current; 32 767 = 500A
00 11	1 is normal; normally closed
00 10	1 is normal; normally open
00 11	1 is normal; normally closed
00 01	0 is normal, normally closed
00 00	FREQ & DFREQ present, 60 Hz nominal frequency
00C8	transmission each two cycles
XXXX	CRC ₁₆

D.3 Data file

The following example shows four data frames that might be found in a data file. They illustrate a system sending two cycle data, or, one sample every two cycles of the power system frequency with five phasors and four digital words.

The following is an example of a data file:

Hexadecimal	Decimal	Quantity
B0 15 58 00	2 954 188 800	SOC
02 28	552	Sample #
30 16	12 310	Status
04 9C	1180	Phasor #1 real
DA 26	-9690	Phasor #1 imaginary
E7 E6	-6170	Phasor #2 real
E7 F8	-6152	Phasor #2 imaginary
F2 75	-3467	Phasor #3 real
27 E4	10 212	Phasor #3 imaginary
EB 37	-5321	Phasor #4 real
12 38	4664	Phasor #4 imaginary
F8 CD	-1843	Phasor #5 real
28 67	10 343	Phasor #5 imaginary
00 00	0	Frequency
00 00	0	df/dt
55 55	21 845	dig channel #1
AA AA	43 690	dig channel #2
55 55	21 845	dig channel #3
AA AA	43 690	dig channel #4
XX XX	—	CRC ₁₆
B0 15 58 00	2 954 188 800	SOC
02 40	576	Sample #
30 16	12 310	Status
04 9C	1180	Phasor #1 real
DA 23	-9693	Phasor #1 imaginary
E7 EB	-6165	Phasor #2 real
E7 F4	-6156	Phasor #2 imaginary
F2 77	-3465	Phasor #3 real
27 E1	10 209	Phasor #3 imaginary

Hexadecimal	Decimal	Quantity
EB 32	-5326	Phasor #4 real
12 32	4658	Phasor #4 imaginary
F8 D2	-1838	Phasor #5 real
28 64	10 340	Phasor #5 imaginary
00 00	0	Frequency
00 00	0	df/dt
55 55	21 845	dig channel #1
AA AA	43 690	dig channel #2
55 55	21 845	dig channel #3
AA AA	43 690	dig channel #4
XX XX	—	CRC ₁₆
B0 15 58 00	2 954 188 800	SOC
02 58	600	Sample #
30 16	12 310	Status
04 9C	1180	Phasor #1 real
DA 20	-9696	Phasor #1 imaginary
E7 EF	-6161	Phasor #2 real
E7 F1	-6159	Phasor #2 imaginary
F2 79	-3463	Phasor #3 real
27 DE	10 206	Phasor #3 imaginary
EB 2D	-5331	Phasor #4 real
12 36	4662	Phasor #4 imaginary
F8 C3	-1853	Phasor #5 real
28 61	10 337	Phasor #5 imaginary
00 00	0	Frequency
00 00	0	df/dt
55 55	21 845	dig channel #1
AA AA	43 690	dig channel #2
55 55	21 845	dig channel #3
AA AA	43 690	dig channel #4
XX XX	—	CRC ₁₆
B0 15 58 00	2 954 188 800	SOC
02 70	624	Sample #
30 16	12 310	Status
04 9C	1180	Phasor #1 real

Hexadecimal	Decimal	Quantity
DA 1D	-9699	Phasor #1 imaginary
E7 F4	-6156	Phasor #2 real
E7 ED	-6163	Phasor #2 imaginary
F2 7C	-3460	Phasor #3 real
27 DC	10 204	Phasor #3 imaginary
EB 28	-5336	Phasor #4 real
12 31	4657	Phasor #4 imaginary
F8 C8	-1848	Phasor #5 real
28 5F	10 335	Phasor #5 imaginary
00 00	0	Frequency
00 00	0	df/dt
55 55	21 845	dig channel #1
AA AA	43 690	dig channel #2
55 55	21 845	dig channel #3
AA AA	43 690	dig channel #4
XX XX	—	CRC ₁₆

Annex E

(Informative)

Sources of synchronization

E.1 Synchronizing source requirements

A synchronizing source must have sufficient availability, reliability, and accuracy to meet power system requirements. Protection and control systems in the power industry operate continuously without interruption. A synchronization source should have continuous uninterrupted availability. The synchronizing signal source must be available to all sites where the data is to be compared. This could range from two sites at either end of a single power line, to an entire utility service area. To be as inclusive as possible, the same signal should be available to the entire region where data might be reasonably compared. The source should be an order of magnitude more reliable than the system requirement since it is the single most crucial element in the synchronizing system.

The synchronizing signal must have sufficient accuracy to assure that the samples are taken at the correct time. Its basic accuracy must be greater than the sampling accuracy requirement. The signal must be repeated often enough to keep the sampling clock within the sampling accuracy requirement. The maximum sampling timing error E_t in second is as follows:

$$E_t = E_s + R_i A_c$$

where

- E_s is the synchronizing signal maximum error in seconds
- R_i is the repetition interval in seconds and
- A_c is the sampling clock accuracy figure (a ratio of seconds/seconds)

A GPS based 1 PPS synchronizing signal with a maximum error of 1 μ s coupled with a $10E-6$ sampling clock yields a combined error of 2 μ s.

E.2 Broadcasts from satellites

Satellite broadcast timing has significant advantages over other timing systems. Satellites have a wide area of coverage. The signal is little affected by atmospheric conditions or seasonal variations. The time signal is continuously referenced to a national standard. Cost is low because the primary reference and time dissemination system are provided by the satellite system sponsor.

The principal problem with satellite broadcasts has been control. All satellite broadcast systems have been put up for purposes other than time dissemination. During crises the primary purposes take priority, and timing function users have occasionally lost access. Satellite systems are expensive to put up and maintain, so the time function user is also at the mercy of funding provided for the primary satellite system function.

For most users, the advantages still make satellite systems worth the risk. As time becomes more critical in applications, users will need to invest more in backup or alternative systems. They will also demand more reliability from government provided services. The need for industry support is being recognized, and timing users are receiving a higher priority. It is expected that satellite based time will eventually be provided with the reliability sought by the power industry, though at that point funding may be by subscription fees.

Transit, GOES, and GPS are the three principal satellites systems available in 1996 for disseminating time. The INMARSAT system should also provide precise time in GPS-like format once policy issues are resolved.

Transit is the oldest of these services and is due to be phased out in 1997. It is a Navy satellite navigation system whose signal can be decoded for time synchronization. It has a reliable 10 μ s accuracy but poor availability due to few satellites. With these limitations, it is not a viable alternative for phasor time synchronization.

The GOES system's primary mission is weather monitoring, particularly for hurricane activity in the Western Hemisphere. The system consists of two geostationary satellites situated to provide coverage across the entire United States. Due to satellite failures, the system has occasionally been reduced to one operating unit, leaving some areas without usable time reception. Small dish antennas are frequently used and must be readjusted if the satellites are moved. The radio link at 468 MHz suffers some interference problems with land based mobile communications and outages due to solar eclipses in the spring and fall. It provides a time synchronization referenced to UTC with a base accuracy of 25 μ s, although a more realistic operating accuracy is 100 μ s. Overall, it provides a synchronizing signal that is marginally acceptable for phasor measurements.

The Global Positioning System (GPS) is a United States Department of Defense (DoD) satellite based radionavigation system. Completed in 1994, it consists of 24 satellites that circle the earth twice a day in six orbital planes. Range and time is broadcast on three L-band frequencies. Time can be derived from the C/A code transmitted at 1575 MHz.

Each satellite modulates the 1575 MHz signal with a unique pseudo-random (PN) sequence that spreads the signal power over a wide bandwidth. The spread spectrum makes the signal resistant to interference. Code division multiplexing allows many satellites to share the same frequency. The signal can be received by a simple omnidirectional antenna. The receiver applies the same PN code to the received signal to de-spread it and acquire precise synchronization with the satellite signal. The distance from each satellite can be calculated by comparing receiver time with the satellite time; that is, distance is the time the signal takes to travel from the satellite to the receiver traveling at the speed of light. Receiver position is determined by triangulating the distance from three satellites using a fourth satellite signal as a time reference. If time or any receiver coordinates are known, fewer satellites are required. A receiver in fixed position needs only one satellite to determine time. Additional information is modulated on the satellite signal including time of day, position, and other system parameters.

GPS is steered by a ground-based Cesium clock ensemble, which itself is referenced to Coordinated Universal Time (UTC), the world standard. Each satellite provides a correction to UTC time that the receiver automatically applies to the outputs. With this continuous adjustment, timing accuracy is limited only by short term signal reception whose basic accuracy is 0.2 μ s. That baseline accuracy can be improved by advanced decoding and processing techniques. For general applications, a 0.5 μ s accuracy is a safer figure to depend on. The short term frequency accuracy of the received signal is on the order of 1×10^{-11} .

A number of considerations make GPS a system that is very available, reliable, and accurate. DoD designed to provide navigation throughout the world without fail in the worst conceivable scenarios, including all weather, system degradation, and interference conditions. With a minimum of four satellite coverage at all times, even sites with restricted sky view are unlikely to lose signal reception. The spread spectrum decoding technique has a high inherent rejection of other signals and noise. Interference from other systems at 1.5 GHz is minimal. Atmospheric conditions and power system noise have been found to have little influence on signal reception. The antennas do not need to be pointed. The receivers are mostly digital and require little tuning or adjustment. Large receiver circuit portions can be built on VLSI chips, reducing the overall chip count for higher reliability.

The only requirement for a phasor system synchronizing signal that GPS does not clearly meet is the access issue. There is still some uncertainty that civilian use will be supported at a level acceptable to the power industry. Congress directed the DoD and the Department of Transportation (DoT) in 1978 to develop a plan for joint use of GPS, rather than spending large sums on both military and civilian systems. GPS was to be further examined as a replacement for older civilian and military systems for additional cost savings. However, GPS has proven successful beyond expectations and the DoD has concerns that a system open to general civilian use may be used by a military adversary. To address these concerns, they have degraded the accuracy of the C/A signal with a process called Selective Availability (SA), and have encrypted the precise signal. Neither of these have a significant effect on timing required by power systems, but the possibility of further restrictions is an issue of concern.

These issues are being resolved as the DoD and DoT jointly develop the *Federal Radionavigation Plan (FRP)* (see [B2]). It basically details what radio navigation aids will be provided by the U.S. government and gives a timetable for their availability. The plan commits GPS to be made available to civilian users at all times except in a national emergency. It limits the inaccuracy introduced by SA so that 92% of the time it will not exceed 0.5 μs and 99.9% of the time it will not exceed 1.1 μs . It also commits the U.S. to provide the signal worldwide without fee for a minimum of 10 years. The FRP is updated every two years, usually in the direction of more civilian access. The large and growing base of users in many diverse applications exerts enough influence that withdrawal of civilian access is unlikely.

The International Maritime Satellite System (INMARSAT) is a series of satellites in geostationary orbits put up for maritime communications and navigation. The new satellites being built for launch in 1995 include a transponder capable of transmitting a GPS-like signal. No SA will be applied, allowing time reception at full precision. Since it is a commercial enterprise, there is little risk that it will be shut down for military purposes. The only real drawback is that geostationary signals are very low on the horizon in the northern latitudes, making reception difficult at some sites. The GPS-like signal should allow reception with existing GPS equipment with only minor modifications.

Overall, the use of GPS for phasor systems synchronization looks very promising. All requirements are well met, the system is well funded for the foreseeable future, and areas of doubt are becoming resolved. GPS is recommended as the synchronizing source of choice.

E.3 Broadcasts from a central location

A variety of alternatives exist for synchronization of remote measurement units using a signal from a central location that has been sent to all the measurement units at the same time. Among the available systems the following groups exist:

- AM radio broadcasts
- Microwave transmission systems
- Fiber-optic transmission systems

AM radio broadcasts are the least expensive, but due to a variety of problems with their implementation, their accuracy is very limited (to a few milliseconds). Both microwave and fiber-optic circuits require substantial hardware and maintenance investment while reaching the accuracies of 1 μs or better. It should also be noted that leased wire line circuits could also be used in place of microwave or fiber systems. However, the user generally has no control over long distance circuits. Routing changes, costs, and reliability combine to make this method undesirable.

The AM radio broadcasts are among the most popular and affordable ways to disseminate time information. The transmitting medium is the atmosphere via electromagnetic waves, hence no hardware investment is needed and the receivers may be placed anywhere. The transmitters are land-based. The most commonly used radio stations in the U.S. are WWV, WWVB, and WWVH (transmitting from Colorado and Hawaii). When distance between the transmitter and receiver is known, the propagation delay can be accounted for and the theoretical accuracy limit is about 100 μs .

Unfortunately, propagation delays in AM transmission are difficult to account for, since the signal can travel both by sky wave and ground wave. The difference in propagation delay between these modes can be several milliseconds, and occasionally the modes can cancel each other. Due to this lack of reliability and accuracy, these broadcasts are not adequate for use as a synchronization source.

Loran C solves these problems by transmitting discontinuous (impulse) signals. Receivers easily differentiate and lock onto the ground wave only. Once the exact location of the receiver is known, the delay is fixed and can be calculated. Only one station needs to be tracked to provide accurate synchronization. Timing accuracy can reach 200 ns, although 1 μs is a more typical and reliable number.

Loran C signals are very stable and continuously available around the clock. The system is funded in the U.S. through the year 2000 and actively supported by a number of other countries. Timing is controlled by atomic clocks and referenced to UTC. However, the signal does not contain time stamp data, and therefore an additional coarser time reference (such as WWV or WWVB) may be needed to establish initial synchronization within 10 ms. A big problem with application of Loran C in substations is its inherent sensitivity to electrical interference, noise, and corona. Power line carrier in the 100 kHz frequency range causes direct interference. Corona causes noise in the same frequency range that degrades performance. For reliable performance careful monitoring is required, a great disadvantage for unattended operation in substations.

A utility may prefer to keep its primary frequency and time source at a central site with transmission to many remote sites. A time code signal output from the central site may then be transmitted via microwave or fiber-optics to equipment requiring synchronizing. The best resolution using microwave facilities approaches 1 μ s by utilizing direct phase shift modulation of a continuous wave signal on the baseband. The baseband requirements are about 60 kHz of spectrum. Fiber-optic transmission would be similar, but could achieve higher accuracy due to the greater bandwidth available and lower noise.

This method works for analog microwave but is difficult to implement on digital microwave and fiber-optic systems. Digital systems gather slower rate data into packets and send them over the main high speed link. The time delays from one packet to the next may be as great as 70 μ s resolution over several hops, but greater accuracy requires custom facilities. Custom fiber-optic links not used for data transmission routinely achieve synchronizing accuracy of 10 ns and better.

Annex F

(Informative)

Time and synchronization formats

F.1 One pulse per second (1 PPS)

The 1 PPS signal shall be a positive pulse at least 5 μ s wide and have a rise time less than 50 ns. It shall be capable of driving a 50 Ω load to at least 5 V over 50 m of RG-58 cable.

F.2 IRIG-B format

IRIG-B is fully described in IRIG STANDARD 200-89, published by the Range Commanders Council of the U.S. Army White Sands Missile Range. The minimum format shall be B122, which has seconds through day-of-year coded in BCD and amplitude modulated on a 1 kHz carrier. Information needed for continuous precision timekeeping shall be added to the code in the control functions as described below. Straight binary seconds may be added as allowed in the standard, but shall not be required by either transmitting or receiving equipment. The amplitude shall be 1–6 V peak-to-peak for the mark (peak), with a mark-to-space amplitude ratio 10:3, as provided in the standard. The time code format is as follows:

<sync> SS:MM:HH:DDD <control> <binary seconds>

where

<sync>	is the on-time sync marker
SS	is the second of the minute [00 to 59 (60 during leap seconds)]
MM	is the minute of the hour (00 to 59)
HH	is the hour of day in 24 format (00 to 23)
DDD	is the day of year (001 to 366)
<control>	is a block of 27 binary control characters
<binary seconds>	is a 17 b second of day in binary

F.3 Control bit assignment

By using IRIG-B with additional extensions, old and new time sources and time users can be easily integrated. PMUs should be programmed to check the control bit field and use this additional information where it is provided, but rely on user-entered data where it is not. Where possible, these new assignments are made with zero indicating a normal state since unused control field bits are normally set to zero. This will minimize the possibility of creating a false alarm. For example, if a control field was all zeroes, the time quality code would indicate the clock was locked with full accuracy that would not accidentally be interpreted as an error condition.

Virtually every timekeeping system is run by some kind of processor. Since IRIG time code numbers arrive AFTER the on-time mark, the timekeeping system must generate the time-tag based on the anticipated number, rather than on what it just got. Consequently, time counts that are not in exact sequence require advance notice. Non-sequence clock counts include leap year, leap second, and daylight savings time changes. The leap second and daylight savings change bits warn of impending special clock counts, and the last two digits of the year alert the timing system of leap year changes.

As an interpretation of the IRIG standard, BCD time and Straight Binary Seconds (SBS) should always be consistent. If BCD time changes by an hour for a daylight time change, SBS should change at the same time to reflect a consistent count. The year will rollover with BCD time regardless of whether it corresponds with UTC time.

Table F-1—Control bit assignments

IRIG-B Pos ID	CTRLB IT#	Designation	Explanation
P 50	1	Year, BCD 1	Last 2 digits of year in BCD
P 51	2	Year, BCD 2	IBID
P 52	3	Year, BCD 4	IBID
P 53	4	Year, BCD 8	IBID
P 54	5	Not used	Unassigned
P 55	6	Year, BCD 10	Last 2 digits of year in BCD
P 56	7	Year, BCD 20	IBID
P 57	8	Year, BCD 40	IBID
P 58	9	Year, BCD 80	IBID
P 59	—	P6	Position identifier # 6
P 60	10	Leap second pending (LSP)	Becomes 1 up to 59 s BEFORE leap second insert
P 61	11	Leap second (LS)	0 = Add leap second, 1 = Delete leap second
P 62	12	Daylight saving pending (DSP)	Becomes 1 up to 59 s BEFORE DST change
P 63	13	Daylight savings time (DST)	Becomes 1 during DST
P 64	14	Time offset sign	Time offset sign—0 = +, 1 = -
P 65	15	Time offset—binary 1	Offset from coded IRIG-B time to UTC time IRIG coded time plus time offset (including sign) equals UTC time at all times (offset will change during daylight savings)
P 66	16	Time offset—binary 2	
P 67	17	Time offset—binary 4	
P 68	18	Time offset—binary 8	
P 69	—	P7	Position identifier # 7
P 70	19	Time offsets—0.5 hour	0=none, 1=additional 0.5 h time offset
P 71	20	Time quality	4 b code representing approx. clock time error 0000 = clock locked, maximum accuracy 1111 = clock failed, data unreliable.
P 72	21	Time quality	
P 73	22	Time quality	
P 74	23	Time quality	
P 75	24	PARITY	Parity on <i>all</i> preceding <i>data</i> bits
P 76	25	Not used	Unassigned
P 77	26	Not used	Unassigned
P 78	27	Not used	Unassigned
P 79	—	P8	Position identifier # 8

F.3.1 Year

The last two digits of the year is in straight BCD in the same format as the rest of the IRIG-B code and follows first after day of year. It will rollover with the day-of-year in the BCD time count.

F.3.2 Leap second

The leap second pending (LSP) and polarity (LS) bits show that one is about to happen and whether it will be inserted or deleted. Leap seconds have only been positive for the last 20 years, so $LS = 0$ is almost certain. The LSP bit should be asserted at least 1 s and less than 60 s before the hour it is to be inserted. The bit should go to 0 when the second count goes to 00. Leap seconds are always inserted at UTC midnight by altering the second time count only. Thus, in UTC time the time count goes from 23:59:59 to 23:59:60 to 00:00:00 to add the extra second. In another time zone, say Pacific Standard Time, 8 h behind UTC, the same count will be 15:59:59 to 15:59:60 to 16:00:00. SBS should give the count 57 600 (=16:00:00) twice.

F.3.3 Daylight savings

The Daylight Savings Pending (DSP) and Daylight Savings Time (DST) bits indicate that a change is about to happen and whether daylight savings is in effect. If $DST = 0$, then the impending change will be to ON, which will delete 1 h from the time scale (leap forward 1 h in the spring) and the Daylight Savings bit will go to one. If $DST = 1$, the opposite will occur. Daylight time changes will be 1 h and are asserted at the minute rollover. The DSP bit should be asserted at least 1 s and less than 60 s before time is to be changed. The DSP and DST bits should change at the same time between the 59 s and 00 s counts. In the U.S., where the time change is put into effect at 2 a.m., the time count in the spring is 01:59:59 to 03:00:00. In the fall, the count is 01:59:59 to 01:00:00.

F.3.4 Local time offset

The local time offset is a 4 b binary count with a sign bit. An extra bit is included for an additional 1/2 h offset used by a few countries. The offset gives the hours difference (up to ± 16.5 h) between UTC time and the IRIG-B time (both BCD and SBS codes). Adding the offset to the IRIG-B time using the included sign gives UTC time (e.g., if the IRIG-B time is 109:14:43:27 and the offset is -06 given by the code 0110 (.0), then UTC time is 109:08:43:27). The local time offset should always give the true difference between IRIG code and UTC time, so the offset changes whenever a daylight savings time change is made. Keeping this offset consistent with UTC simplifies operation of remote equipment that uses UTC time.

F.3.5 Time quality

A 4 b time quality indicator is used by several manufacturers and is in several existing standards. It is an indicator of time accuracy or synchronization relative to UTC and is based on the clock's internal parameters. The code recommended here is by order of magnitude relative to 1 ns. It is basically the same as used in the HaveQuick and STANAG 4430 (NATO) time codes, but with a more practical scale. The 1 ns basic reference is fine enough to accommodate all present industry uses now and into the foreseeable future. With present GPS technology at the 100 ns accuracy level, a 0000 code indicating locked will go to a 0011 or a 0100 code at unlock.

F.3.6 Parity

A parity bit is easy to implement by simply adding all the bits in the message from BCD seconds through the time quality control bits. (Straight Binary Seconds would not be included.) It provides some assurance the data is correct and a secondary verification that the control bit field has been implemented. An unused bit could not be mistaken for parity, since parity will change each second most of the time as the second count increments. The last three unused bits are left after the parity for user specific assignment without affecting this code. They could be used for higher order bits in a 4 b parity or LRC.

Table F-2—4 b quality indicator code

Binary	Hex	Value (worst case accuracy)
1111	F	Fault—clock failure, time not reliable
1011	B	10 s
1010	A	1 s
1001	9	100 ms (time within 0.1 s)
1000	8	10 ms (time within 0.01 s)
0111	7	1 ms (time within 0.001 s)
0110	6	100 μ s (time within 10^{-4} s)
0101	5	10 μ s (time within 10^{-5} s)
0100	4	1 μ s (time within 10^{-6} s)
0011	3	100 ns (time within 10^{-7} s)
0010	2	10 ns (time within 10^{-8} s)
0001	1	1 ns (time within 10^{-9} s)
0000	0	Normal operation, clock locked

F.4 High precision time code format

IRIG-B format transmitted using modified Manchester modulation is recommended as an alternative to the AM modulated IRIG-B with separate 1 PPS sync. This modulation is better adapted for both fiber and metallic digital systems. With the previous control bit assignments, this time code format can serve all power industry requirements now and in the foreseeable future.

Manchester coding provides a 0 mean code that is easy to decode, even at low signal levels. The 1 kHz clock provides a precise on-time mark that is always present. The coding method mimics 1 kHz modulated IRIG-B with binary 1s and 0s in place of high and low amplitude cycles. A Manchester binary 1 is equivalent to a high amplitude cycle in the AM modulation and a binary 0 indicates a low amplitude cycle. Using this modulation, an IRIG-B code "0" will be two 1s followed by eight 0s. An IRIG-B code "1" will be five 1s followed by five 0s (see figure F-1). This conversion keeps the codes compatible and makes translation or regeneration of the AM IRIG-B very simple.

Modified Manchester modulation is not included in the IRIG standard, so this is not an IRIG code. However, the Range Commander's Council is considering adding a Manchester modulation into the IRIG standard. This or a similar Manchester modulation format may be specified by 1997; users of this standard should consult IRIG and IEEE-PSRC for the most recent recommendation.

F.5 Modified Manchester coding

Manchester modulation or encoding is a return-to-zero type where the pulse transition indicates binary 0 or 1. In this case, a 1 kHz square wave is the basic clock modulated by the data to produce a rising edge to indicate a binary one (1) and a falling edge to indicate a binary zero (0). The transition at every data bit provides good receiver synchronization. Each bit period is half high and half low, so the mean is always half, making it easy to decode even at low levels. In standard Manchester coding, the data edge occurs in the middle of the clock window to indicate a binary one or zero. Since there is a data bit (i.e., transition) every clock period, it is easier to synchronize on the data than the clock cycle. The "modification" moves the data window so the data is at the edge of the clock window that is on time with UTC (see figure F-2). In another view, the modification simply defines the middle of the window as "on time." What is important is that the data edge is the "on time" mark in the code. This simplifies the construction of readers and regeneration of the other IRIG code forms.

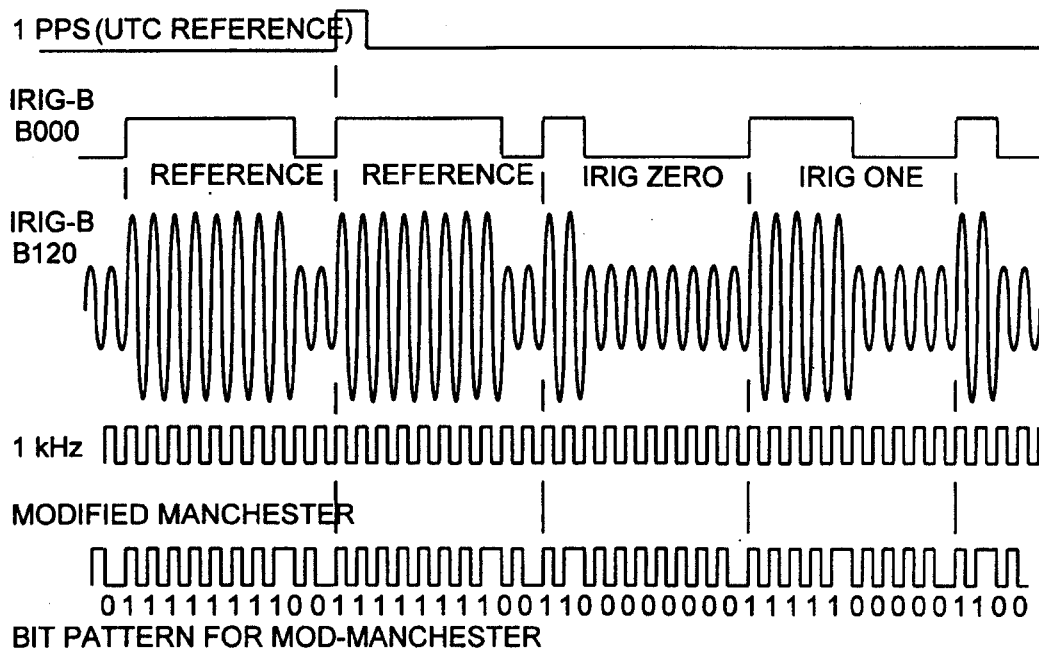

Figure F-1—IRIG-B coding comparisons: level shift, 1 kHz AM, and modified Manchester

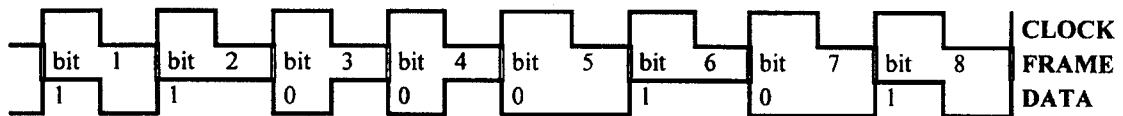

Figure F-2—Modified Manchester coding

Annex G

(Informative)

Alternative synchronization methods

Clause 5. defines an algorithm for synchronization of the phasors by phase-locking the sampling clock to a time reference. Alternative methods exist that meet the other requirements of this standard for producing synchronized phasors. The following is one of the alternative methods.

For the purpose of direct comparison of phasors at different locations within a power system, each phasor must have a common time and angular relationship, a common data format, and a common time reference. UTC has been chosen as the time base for the reason previously shown. The common phasor format has also been described earlier. This annex describes an alternative method for giving phasors a common time and angular relationship.

Synchronization is accomplished by forcing all phasors to be directly referenced to the synchronized 1 PPS. This synchronization can be achieved by establishing an angular reference to allow the measured phasors to be referenced to a common angle with an equivalent angular accuracy. The required level of precision for the synchronized sampling method is 1 μ s, and the corresponding angular reference precision is 0.022 degrees for a 60 Hz system and 0.018 degrees for a 50 Hz system.

It is not necessary to force the individual samples to be phase-locked to a time reference in order to achieve direct phasor comparison. The same result can be achieved by forcing the samples to be phase-locked to local frequency. Using adaptive sampling to adjust the time between samples, from which the phasors are calculated, automatically avoids "leakage" effect (see [B1]) caused by off-nominal power system frequencies. Under the conditions shown in 5.5, the two methods will lead to identical phasors.

Phase-locking the sampling can also permit calculation of mixed quantity engineering units (watts, VARs, apparent impedance, etc.) during the same cycle that the phasors are calculated. The data format will then allow real time transmission of mixed quantities expressed as complex numbers as well as the voltage and current phasors.

The 1 μ s level of precision has been chosen because of the availability of synchronization sources capable of this accuracy. Depending upon the particular application, less demanding synchronization precision may be satisfactory. If analog or digital processing of the sampled data produces a phase shift that effectively gives rise to errors in either the sampling times or phase angle reference, these errors must be corrected and may be included as part of the header information so that comparison between different systems can be made.